

REV. A	ECN NUMBER RELEASED	DATE 2010/01/11
-----------	------------------------	--------------------

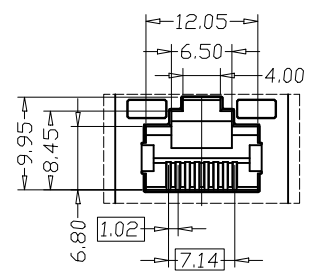

DETAIL: A
SCALE:1:1

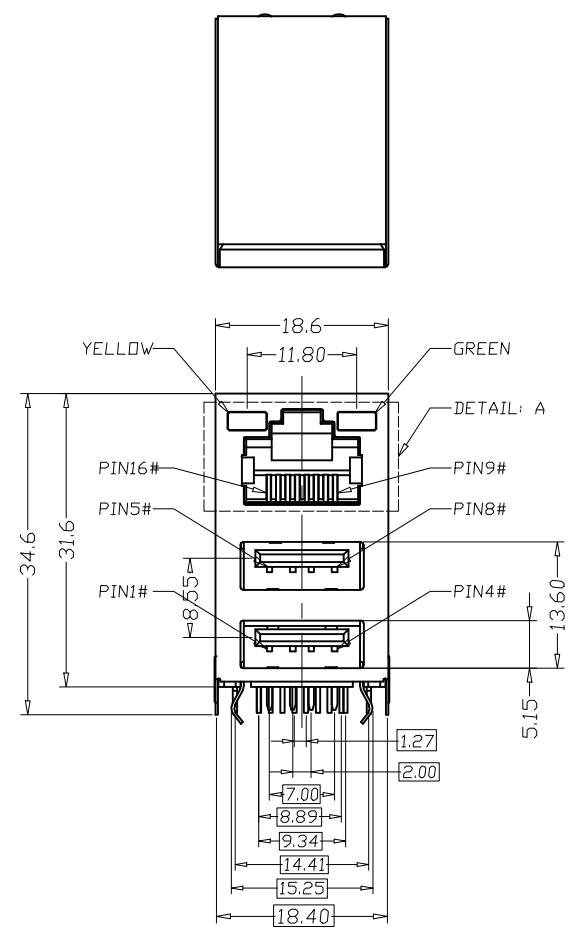
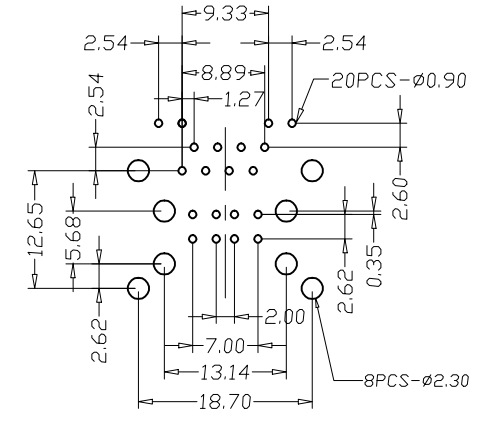
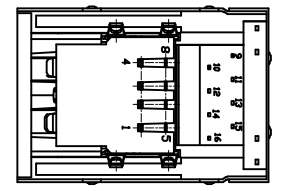
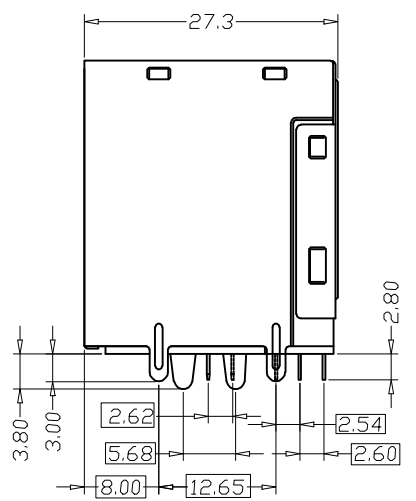

RECOMMEND P.C.B LAYOUT
TOLERANCE:±0.05MM

- NOTES:
- MATERIAL:
 - HOUSING: PBT+30%G.F UL94V-0
 - CONTACT
 - USB SPRING: SPCC, T=0.30±0.02mm
 - USB CONTACT: BRASS C2680, T=0.25±0.02mm
 - USB SHELL: SPCC, T=0.30±0.02mm
 - RJ45 CONTACT: PHOSPHOR BRONZE, C5210-H, T=0.30±0.02mm
 - RJ SHELL: SPCC, T=0.30±0.02mm
 - PLATING:
 - RJ45 SHELL:
 - 80u" MIN COPPER UNDERPLATING ALL AREA, 50u" MIN NICKEL OVERALL
 - USB:
 - 100~150u" NICKEL PLATING OVERALL, 80u" MIN. COPPER UNDERPLATING OVERALL
 - USB AND RJ45 CONTACT:
 - GOLD FLASH PLATING ON CONTACT AREA
 - 100~150u" TING PLATING ON SOLDER TAIL AREA
 - 50~100u" NICKEL UNDERPLATING OVERALL

備注：重點尺寸標示☒

DIMENSIONS TOLERANCE	
METRIC	
.0	±0.25
.00	±0.20
.000	±0.15
.0000	±0.XXX
ANG.	±2°

單位(UNITS)	mm	Coorle 库乐科技 圖名(NAME) RJ45+双层USB+LED灯 成品 RoHS			
數量(QT'Y)	N/A				
材料(MT'L)	SEE NOTE				
處理(FINISH)	SEE NOTE				
繪圖(DRAW)		料號(PART NUMBER)			
設計(DE'N)		圖號(DRAW NUMBER)			
審核(CH'K)		圖檔(FILE NAME .DWG)			
核准(APP'D)		比例(SCALE)	1/1	圖紙(SIZE)	A4
		頁次(SHEET)	1	版次(REV.)	A